

# Technical Instruction Manual

## DORROUGH STEREO SIGNAL TEST SET Model 1200

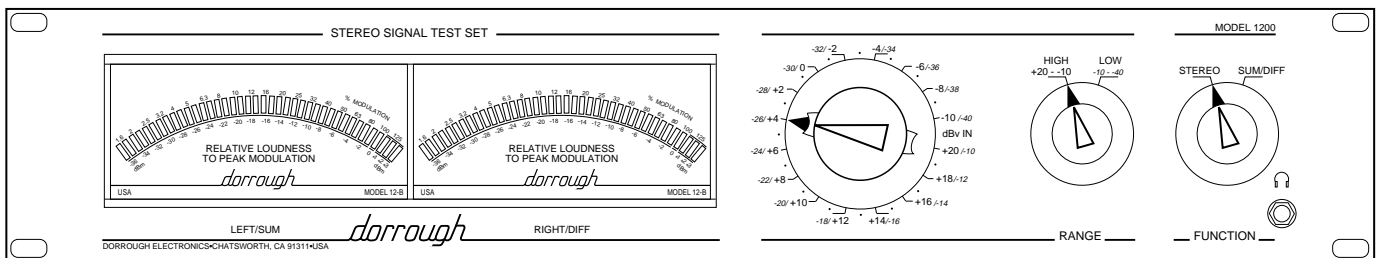

*dorrough*

DORROUGH ELECTRONICS  
5221 Collier Place  
Woodland Hills, CA 91364  
(818) 999-1132

# INTRODUCTION

The DORROUGH Stereo Signal Test Set, Model 1200, is a simple and easy-to-operate gain set that will allow you to quickly monitor and dynamically balance stereo broadcast lines. The Model 1200 offers the widest range ever designed for accurate measurement of level, balance, crosstalk, and signal-to-noise of your system from noise floor to signal clipping. Now you can easily verify stereo system performance without having to call for an oscilloscope or DVM from the maintenance shop. Yet if incorrect conditions are spotted, just connect test equipment to one of the Monitor Jacks to examine a suspected problem in detail.

## Description

The DORROUGH Stereo Signal Test Set contains a pair of input amplifiers, a precision 30 dB-step RANGE Attenuator, a RANGE Selector offering a selection of two 30 dB measurement ranges, a stereo or sum/difference FUNCTION Selector, a pair of DORROUGH Relative Loudness To Peak Modulation Meters (Model 12-B), and two buffered Monitor Outputs, as shown in block diagram form in Fig.1.

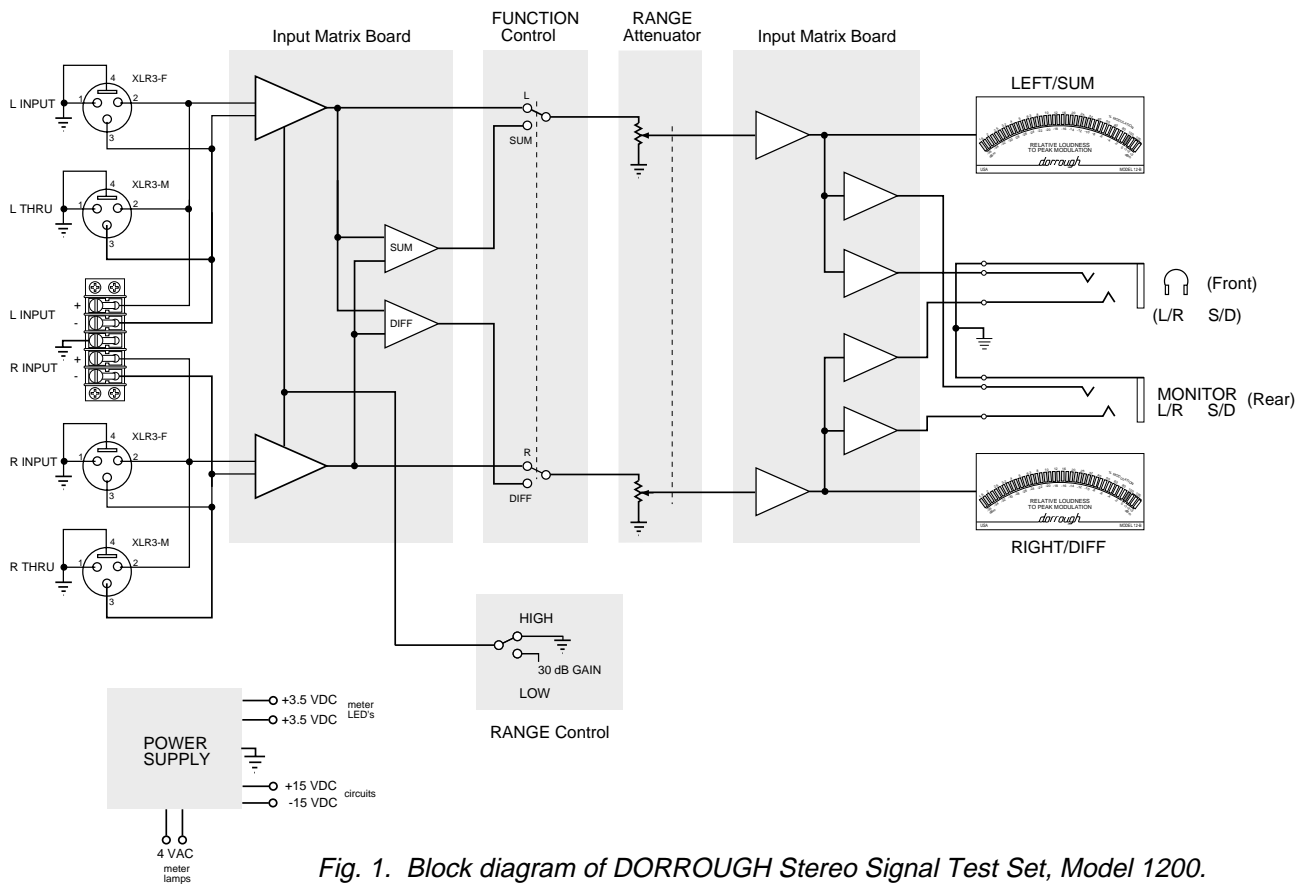

Fig. 1. Block diagram of DORROUGH Stereo Signal Test Set, Model 1200.

The Model 1200 has a measurement range of 96 dB (-76 to +20 dB). The design features inputs that are transformerless and electronically servo-balanced to guarantee a constant gain for all input feed configurations (i.e., balanced, unbalanced, etc.). Barrier strip and parallel XLR connections, with an "audio loop-thru" feature, are included to provide installation flexibility. Input impedance is set at 40 kOhms to insure stereo program monitoring without any loading effects.

The Model 1200 uses two "B" Type LED meters to simultaneously measure true peak and average audio levels over a 40 dB range in 1 dB increments. A reference level is set 3 dB below full scale and is designated as 0 dB or 100% Modulation.

A Monitor Jack is provided on both the front and rear panels for use with an oscilloscope, headphones, or monitor amplifier. The output level of the front jack can be internally set for any gain level up to +20 dB, and both jacks will follow the action of the RANGE attenuator and FUNCTION selector.

## **About This Manual**

This Technical Instruction Manual is divided into the following sections: Installation, Operation, Applications, Circuit Theory, Field Alignment, and Schematics. Before you install the unit, we suggest you take a moment to read through the Operation and Applications sections to fully understand the capabilities of the Model 1200. After you have determined how best to use the DORROUGH Stereo Test Set for your purposes, then follow the instructions listed in the Installation section.

# INSTALLATION

To install your DORROUGH Stereo Signal Test Set, Model 1200, perform the instructions described in the following sections.

## Unpacking

Your DORROUGH Stereo Signal Test Set, Model 1200, was carefully packed at the factory. Take a moment to examine the unit for any signs of shipping damage. If damage is evident, retain the carton and notify the transit carrier and your local distributor about your claim.

Once you are satisfied with the physical integrity of the unit, follow the steps listed below in Initial Set-Up. Upon completion of this section, proceed to the section on Operation and Applications.

## Initial Set-up

1. To rack-mount your Model 1200, locate a ventilated area that provides a minimum depth of 10" for proper cable routing. Consider a location that not only will offer easy observation of the meter movements, but will also allow convenient access to the front panel controls.
2. After mounting the unit, plug the AC cord into a convenient AC line and observe that the two meter displays on the front panel become backlit.



*NOTE: If you do not see this action, check your AC line for power, or test the 3.0 Amp fuse for continuity.*

3. Feed a mono +4 dB test signal (i.e. 1 kHz tone) to the unit through the appropriate LEFT input connection located on the back panel, as shown in Fig. 2.

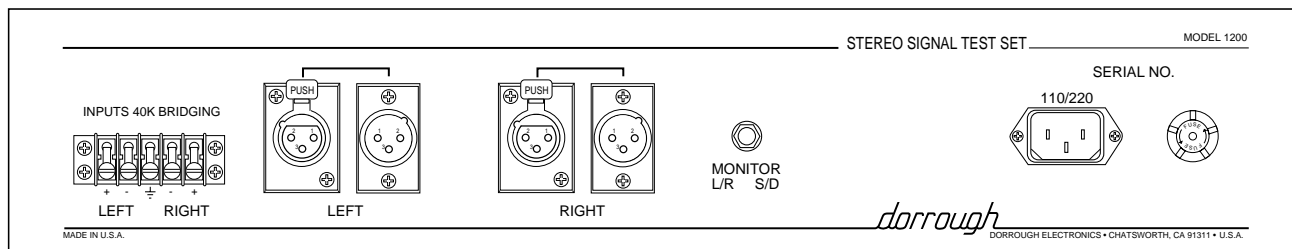

Fig. 2. Rear panel of DORROUGH Stereo Signal Test Set, Model 1200.



*NOTE: The Model 1200 provides you with a choice of barrier strip or XLR connections that are tied together internally. An additional "loop-thru" M-XLR connector is provided at each channel input to facilitate system installation. Because of the servo-balanced input circuits, any XLR wiring convention may be used, as long as both incoming and outgoing L and R cables are wired the same.*

If you do not have a wiring standard, we suggest implementing the following pin assignments:

**BALANCED**

Pin 1 = GROUND  
 Pin 2 = HIGH  
 Pin 3 = LOW

**UNBALANCED**

Pin 1 = GROUND  
 Pin 2 = HIGH  
 Pin 3 = LOW tied to pin 1

- On the front panel, set the FUNCTION control to STEREO and position the RANGE attenuator control to +4 dB, as shown in Fig. 3. Make sure the HIGH/LOW range control is set to HIGH.

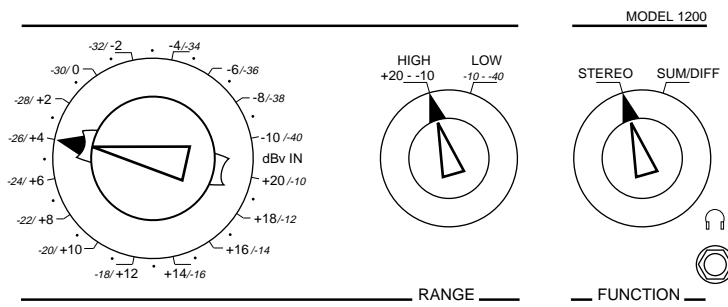

Fig. 3. Initial control settings on Model 1200.

- Verify that the left LED meter indicates 0 dBm, as shown in Fig. 4.

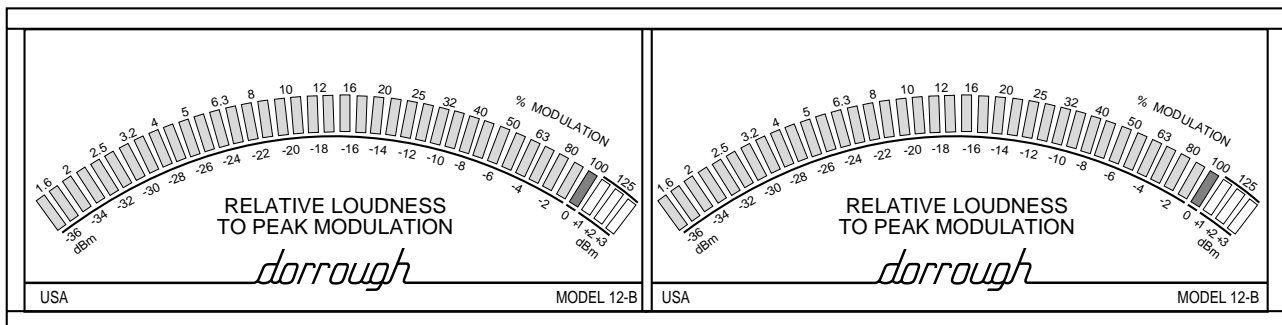

Fig. 4. Example showing Left and Rights meter indicating 0 dB.

- Repeat step 3 for the RIGHT input connection and verify that the right LED meter indicates 0 dBm.

# OPERATION

You can use the DORROUGH Stereo Test Set to quickly measure or verify: Stereo Program Balance, Separation, Crosstalk, Line Polarity, Signal-to-Noise Ratio, Clipping Threshold, and System Headroom. These measurements are all made from the Model 1200 front panel, as shown in Fig. 5.

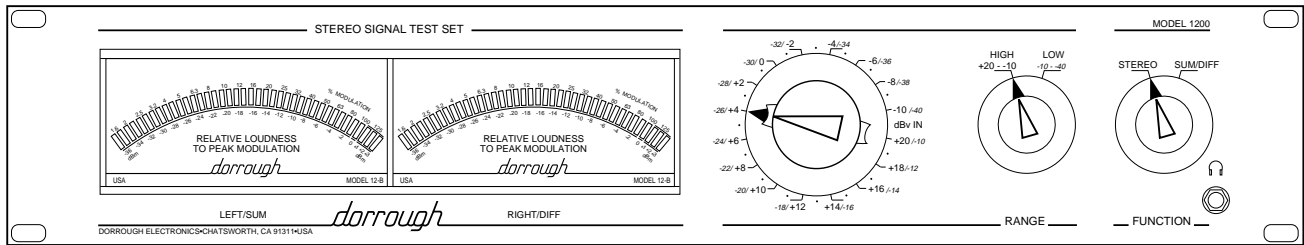
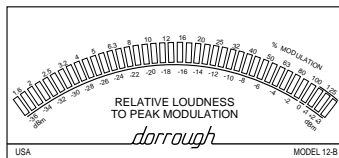

Fig. 5. Front Panel of DORROUGH Stereo Test Set, Model 1200.

## Front Panel Controls

The Model 1200 front panel is equipped with two Relative Loudness to Peak Modulation meters (Type B Scale), a precision 30-step RANGE Attenuator, a HIGH/LOW Range Selector, a FUNCTION Control for selecting either STEREO or SUM/DIFF monitoring, and a Headphone Monitor jack.

## Relative Loudness to Peak Modulation Meters



The Model 1200 uses two Relative Loudness to Peak Modulation meters (Model 12-B) to provide indication of measured audio levels. Each meter is designed to indicate ascending signal levels from left to right across the row of LED's. There are two scales on the meter face plate: a dB scale, graduated in 1 dB increments from -36 dB to +3 dB, and a Modulation scale ranging from 0% to 125% modulation.



*NOTE: A reference level set point is indicated 3 dB below full scale. At this point, a known 0 dB peak audio level can be associated with 100% modulation.*

The "B" Type meter uses the same ballistics as the standard "A" Type meter. To read average signals on this meter, observe the value of the LED's within the consecutively lit bar display. The largest valued LED is the average reading. Peak signal strength is indicated by the single lit LED farthest to the right of the consecutively lit bar display, as shown in Fig. 6.

Fig. 6. An example of peak and average indications for a pink noise source. With test tones (i.e. 1 kHz), the peak and average level indication will coincide with the last illuminated LED having a double brightness.

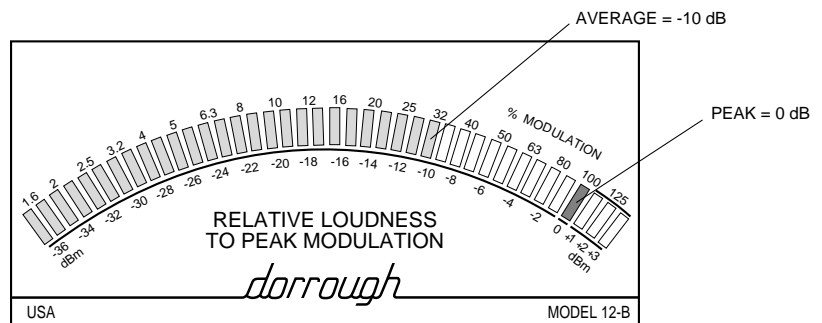

## RANGE Attenuator

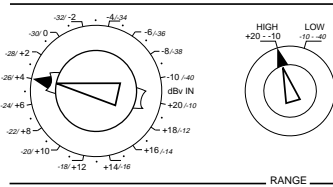

The RANGE Attenuator provides 30 precision steps of attenuation in 1 dB increments. Two scales provide an accurate measurement of the attenuated signal. The HIGH scale ranges from +20 to -10 dB and is used when the HIGH/LOW Range Selector is in the HIGH position.

The LOW scale ranges from -10 to -40 dB and is used when the HIGH/LOW Range Selector is in the LOW position.

## FUNCTION Control

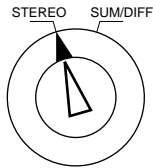

The FUNCTION Control provides two ways of monitoring stereo signals. When STEREO is selected, the left meter displays L audio signal peaks and the right meter shows the R audio signal peaks. When SUM/DIFF is selected, the left meter displays SUM audio signal peaks, and the right meter displays DIFF(erence) audio signal peaks.

When viewing a stereo signal as a SUM signal, you can expect up to 6 dB increase in the meter reading, depending on signal content or correlation.

## Headphone Monitor

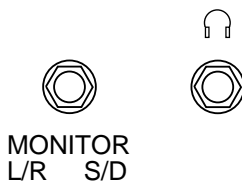

The Model 1200 provides two monitor jacks (front and rear panels) for use in monitoring selected signals and functions. Both jacks follow the RANGE Attenuator as well as the FUNCTION Control selection. In addition, the Headphone Monitor on the front panel is powered by an internal 1W amplifier for driving a stereo headset or a set of small loudspeakers. The Headphone Monitor can be adjusted internally for a nominal loudness level (see Headphone Monitor Adjustment at end of manual).

Keep in mind the following signal assignments when you access either monitor jack:

Tip = LEFT or SUM  
 Ring = RIGHT or DIFF  
 Sleeve = GROUND



**NOTE:** Although the 1W amplifier has acceptable distortion specifications, use the rear panel monitor jack to perform any critical measurements. This connection taps the audio signals before the internal amplifier. If needed, refer to the circuit schematic to locate the signal path to both monitor jacks.

## Measuring A Stereo Signal

This procedure instructs how to use your DORROUGH Stereo Signal Test Set to perform the variety of tests listed in the Applications section. We suggest you take a few moments and try these steps on your favorite stereo program or test signal.

Initially set the RANGE Attenuator to +20 db, the HIGH/LOW Range Selector to the HIGH position, and the FUNCTION Control to STEREO, as shown in Fig. 7.

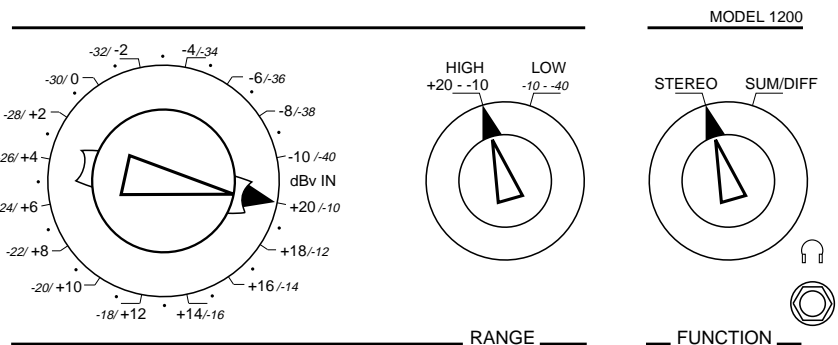

Fig. 7. Initial settings for measuring a stereo signal.

1. Feed a stereo signal (i.e., -10 dB, 0 dB, +4 dB, etc.) through the appropriate connections on the back panel, as described in the Installation section.
2. Turn the RANGE Attenuator clockwise a step at a time while you observe the meters. Continue rotating the RANGE Attenuator clockwise until you see near full scale indications on the meters, as shown in Fig. 8.

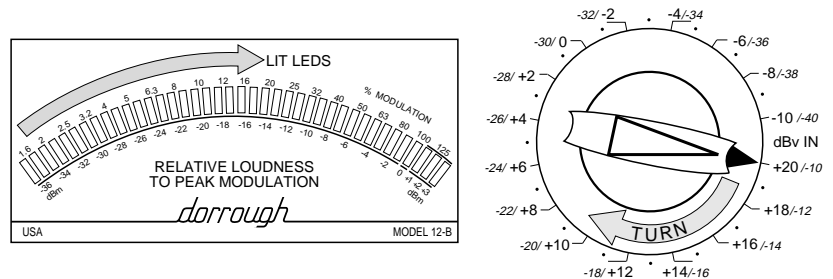

Fig. 8. This example illustrates the action of the LED bar display as the RANGE attenuation is increased (clockwise).



NOTE: If all the LED's are lit, turn the RANGE Attenuator counter-clockwise to attenuate the signal until you see near full scale indications.



- Observe the signal peaks for a moment and turn the RANGE Attenuator in either direction until you see peak signals reaching, but not surpassing, the 0 dB (1st red LED) indication, as shown in Fig. 9.

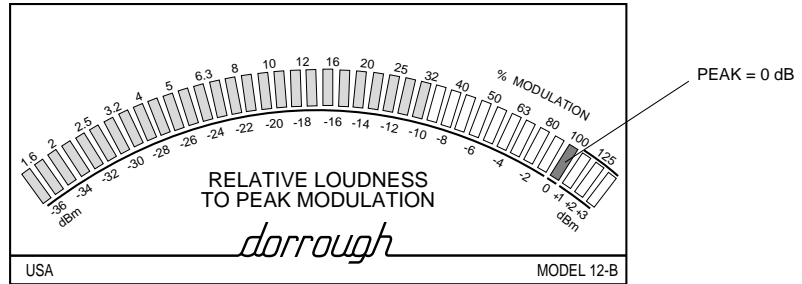
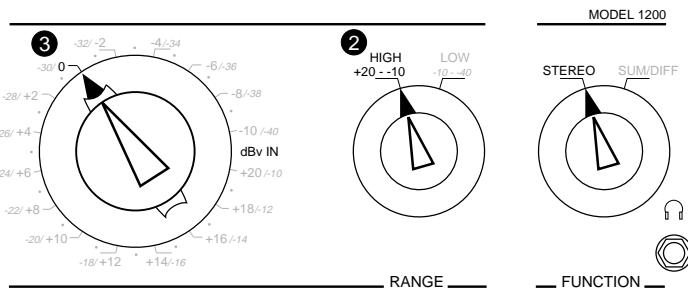
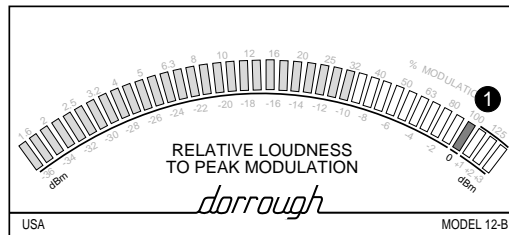

Fig. 9. Reading shows peak signal equal to 0 dB.

- When you are satisfied with the setting, observe the value indicated by the RANGE Control knob on the scale closest to the pointer, as shown in Fig. 10. The indicated value is an accurate measurement of the peak signal strength contained within the stereo audio signal.

Fig. 10. To read the meter in this example, follow this procedure.

- Meter peak LED at 0 dB
- Note RANGE is HIGH
- Read HIGH scale for a 0 dB reading



NOTE: If you are using a lower level stereo signal, you may not see any indication on the meters when you performed the above instructions. If so, position the HIGH/LOW Range Selector to the LOW position and repeat the procedure.

The next section, APPLICATIONS, will provide you with some ideas on how to use your DORROUGH Stereo Signal Test Set.

# APPLICATIONS

Your DORROUGH Stereo Signal Test Set can be used for a number of audio performance tests, including measurements of: System Gain, Polarity and Phase Compatibility, Stereo Signals, System Headroom, System Noise Floor, Crosstalk, and Azimuth.

In addition, you can use your Model 1200 to check the phase polarity compatibility of Dialog/Effects/Music mixes for film and video productions, as well as determine whether dynamic signal processing is needed prior to broadcast or duplication of audio signals.

A test circuit, shown in Fig. 11, shows the signal flow used to perform any of the listed applications. Consider using either pink or white noise as a source for your wide band test signal. As an option, install the Model 1200 with "normalled" audio jacks to constantly monitor a main stereo program. With this type of installation, you can easily perform other audio checks by simply cross-patching the DORROUGH Stereo Test Set to the appropriate signal feeds.

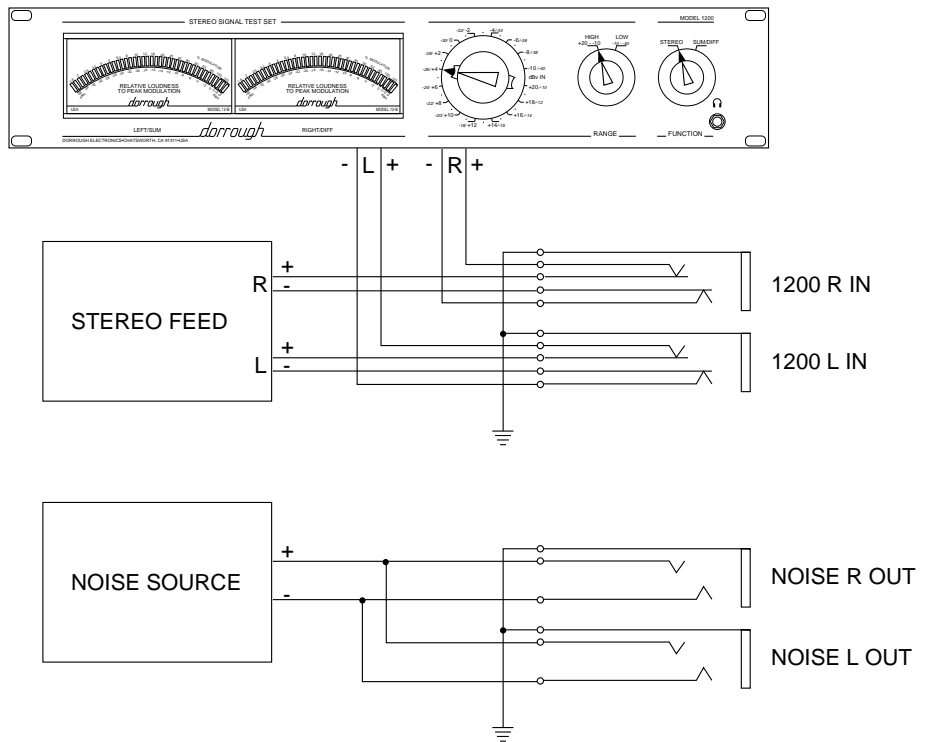

Fig. 11. A suggested test circuit that can be used to quickly perform quality assurance tests at a broadcast installation.



**IMPORTANT:** The meters show peak and average levels simultaneously. Only continuous or constant level tones will indicate identical peak and average levels with a double-bright indication at the last LED of the consecutively lit bar display.

## Measuring System Gain

1. Feed a test signal (i.e., pink noise) at a standard line level to one or both inputs of the device or system you wish to test.
2. Adjust the gain of the device or system under test to its minimum setting.
3. Connect or patch the output(s) of the device or system under test to the inputs of the Model 1200.
4. Set the FUNCTION Control to STEREO, the HIGH/LOW Range Selector to LOW, and adjust the RANGE Attenuator until you achieve a reading closest to 0 dB on the meter(s), as shown in Fig. 12. Make a note of the value on the appropriate scale next to the RANGE knob pointer.

Fig. 12. To read the meter in this example, follow this procedure:

- 1 - Meter peak LED at 0 dB
- 2 - Note RANGE is LOW
- 3 - Read LOW scale for a -30 dB reading

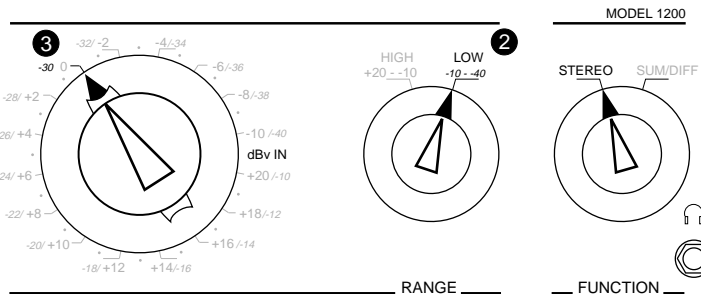
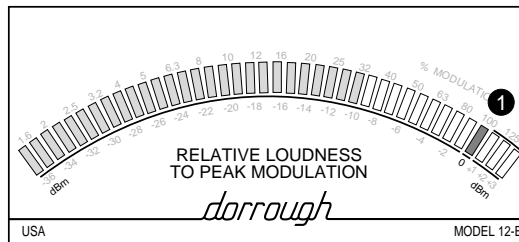

**NOTE:** Depending on the minimum gain setting, you may have to set the HIGH/LOW Range Selector to HIGH to achieve a proper reading. For more information, refer to the Operation section.

5. Adjust the gain of the device or system under test to its maximum setting.



**NOTE:** The actual maximum setting will occur when the peak LED reaches its highest reading. If you continue raising the gain setting, you should see the average reading approach the peak reading, as signal clipping starts to occur.

6. Rotate the RANGE Attenuator in the either direction until you get a reading closest to 0 dB on the meter(s). Make a note of the value on the appropriate scale next to the RANGE knob pointer.



*NOTE: Depending on the amount of gain being introduced, you may have to set the HIGH/LOW Range Selector to HIGH to achieve a proper reading. For more information, refer to the Operation section.*

7. The system gain is the difference between the two values noted in steps 6 and 4.

## Testing For L/R Polarity and Phase Compatibility

1. First, measure the system gain of both Left and Right channels of the device or system you wish to test. Use the method described in Measuring System Gain Application.

If needed, adjust the individual channel of gain settings (of the device or system being tested) so that the Left and Right channels exhibit equal gain structure.



*NOTE: Make sure that any equalization settings added to each channel are set exactly the same or are in the flat or bypassed position.*

2. Feed a known mono signal into both channels of the device or system being tested. Set the FUNCTION Control to SUM/DIFF, and adjust the RANGE Attenuator and HIGH/LOW Range Selector to either setting until you achieve a reading closest to -6 dB on the LEFT/SUM Meter.
3. Set the FUNCTION Control to STEREO and then back to SUM/DIFF. Note the difference in readings on the LEFT/SUM meter as well as the RIGHT/DIFF meter.
4. When SUM/DIFF is selected, two audio channels having the same polarity and no phase problems will exhibit an +6 dB increase on the LEFT/SUM meter. In addition, the RIGHT/DIFF meter will show no reading, as shown in Fig. 13 (page 12).

If the meter readings are reversed, then one of the channels under test has reversed polarity.

If there are readings on both meters, then the phase response of the device or system under test is not flat.



*NOTE: Connect an oscilloscope to the Monitor Jack on rear panel to examine the frequency response of each channel.*

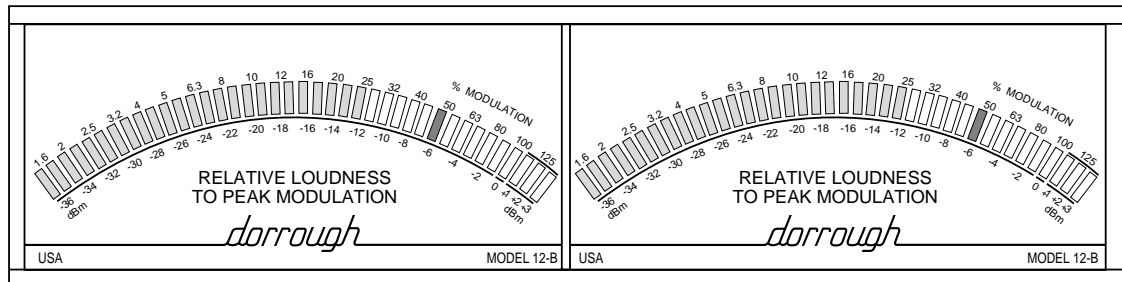

LEFT

RIGHT

(a) An example of a known wide-band mono signal displayed on STEREO meters.

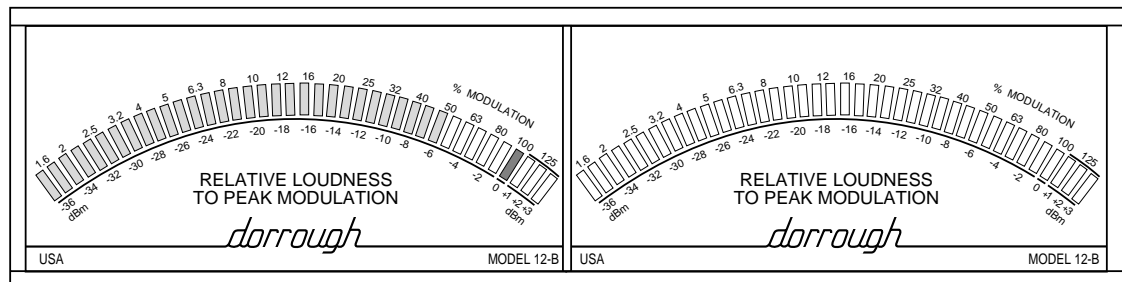

SUM

DIFF

(b) An example of a known wide-band mono signal displayed in (a) above when viewed as SUM/DIFF. A signal having the same polarity and no phase problems will exhibit a 6 dB increase on the SUM meter and no reading on the DIFF meter.

Fig. 13. An example of meter readings with FUNCTION Control set to STEREO (a) and SUM/DIFF (b).

## Testing Stereo Signals

1. First, measure the system gain of both Left and Right channels of the device or system you wish to test. Use the method described in Measuring System Gain Application.

If needed, adjust the individual gain settings so that the Left and Right channels exhibit equal gain structure.

2. Set the FUNCTION Control to SUM/DIFF, and adjust the RANGE Attenuator and HIGH/LOW Range Selector to either setting until you achieve a reading closest to 0 dB on the LEFT/SUM Meter.

3. A stereo signal will provide readings on both the LEFT/SUM and RIGHT/DIFF meters, as shown in Fig. 14. For proper stereo signals, the LEFT/SUM meter will show a higher reading than the RIGHT/DIFF meter. The amount of difference will depend on the amount of correlated signals contained within the audio mix. If you observe a larger reading on the RIGHT/DIFF meter, check the stereo signals for an out-of-polarity condition, as discussed in the Testing for L/R Polarity and Phase Compatibility Application.

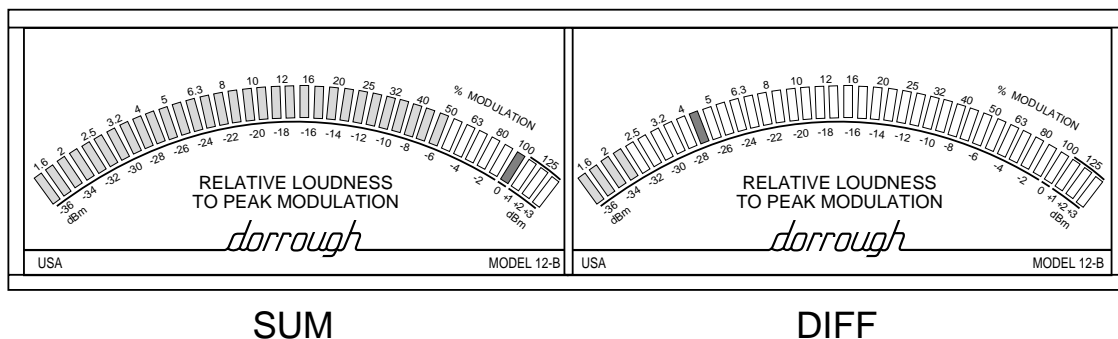

Fig. 14. An example of a SUM/DIFF reading for a typical stereo signal.



*NOTE: If the audio program is highly correlated stereo, the RIGHT/DIFF may only show an occasional reading, or the portion of the audio program you are monitoring may actually contain substantial mono information (i.e. dialog). Use the Monitor Jack on the rear panel to feed an oscilloscope for verification of program content.*

## Testing System Headroom

1. Feed a test signal (i.e., pink noise) at a standard line level to one or both inputs of the device or system you wish to test.
2. Adjust the gain of the device or system under test to its normal operation setting.
3. Connect or patch the output(s) of the device or system under test to the inputs of the Model 1200.
4. Set the FUNCTION Control to STEREO, the HIGH/LOW Range Selector to HIGH, and adjust the RANGE Attenuator until you get a reading closest to 0 dB on the meter(s), as shown in Fig. 15 (page 14). Make a note of the value on the appropriate scale next to the RANGE knob pointer.



*NOTE: Depending on the gain structure of the device or system under test, you may have to set the HIGH/LOW Range Selector to LOW to achieve a proper reading. For more information, refer to the Operation section.*

Fig. 15. To read the meter in this example, follow this procedure:

- 1 - Meter peak LED at 0 dB
- 2 - Note RANGE is HIGH
- 3 - Read HIGH scale for a 0 dB reading

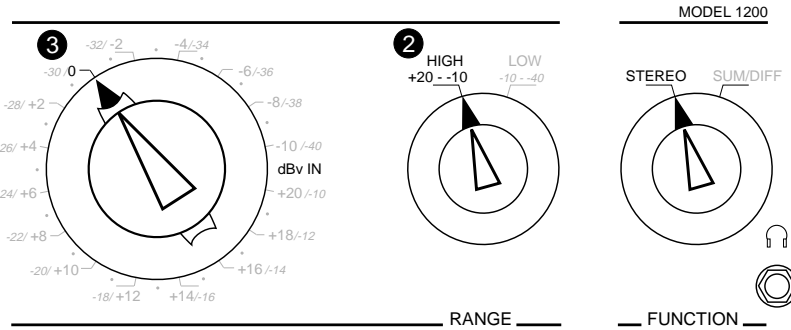
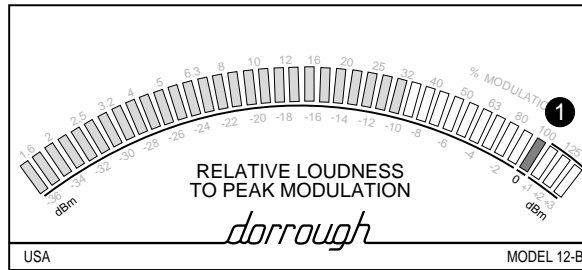

5. Adjust the gain of the device or system under test to its maximum setting.
6. Rotate the RANGE Attenuator switch clockwise and HIGH/LOW Range Selector to either setting until you achieve a reading closest to 0 dB on the meter(s).
7. While observing the meters, slowly lower the gain of the device or system under test. Observe that the average reading will start to drop lower as you lower the gain. Continue lowering the gain until you see a corresponding drop of the peak LED on the meter, as shown in Fig. 16 (page 15).  
  
Stop adjusting the gain, since this is where signal clipping starts to occur and useable system headroom is measured. Readjust the RANGE Attenuator to once again get a reading closest to 0 dB on the meter. Make a note of the value on the appropriate scale next to the RANGE knob pointer.
8. The system headroom is the difference between the two values noted in steps 7 and 4.

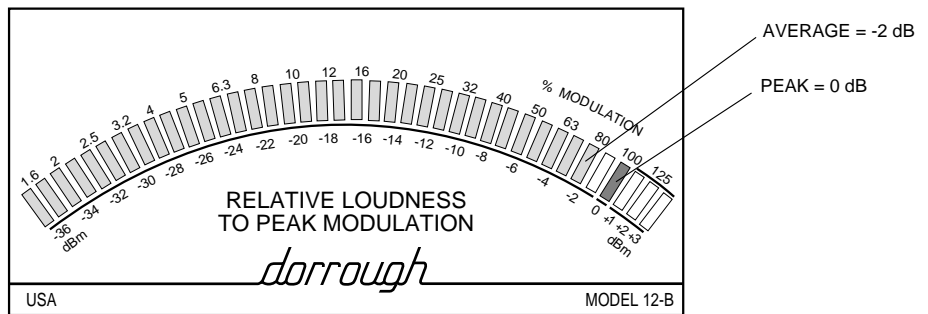

(a) In this example, gain is set to maximum and results in an average reading of -2 dB and a peak reading at 0 dB. This type of indication shows the system or device is producing distortion products from signal clipping, as the difference between peak and average readings is only 2 dB.

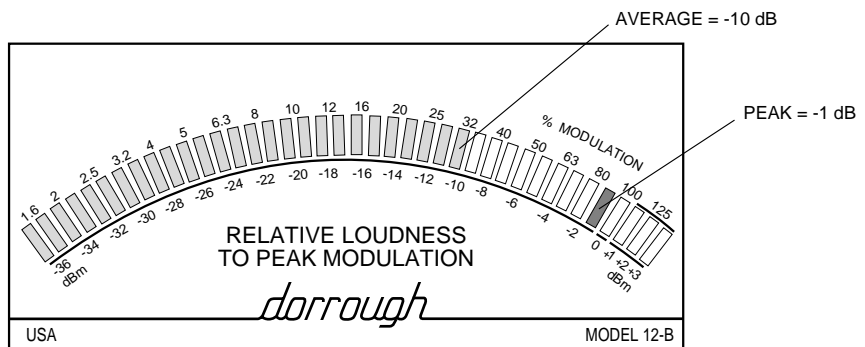

(b) When the gain is lowered from (a) above, note that the average reading drops dramatically. When the peak reading drops 1 dB, the true, undistorted headroom gain setting is achieved.

Fig. 16. An example of maximum gain set for testing of system headroom.

## Testing System Noise Floor

1. Feed a test signal (i.e., pink noise) at a standard line level to one or both inputs of the device or system you wish to test.
- 2.. Adjust the gain of the device or system under test to its normal operation setting.
3. Connect or patch the output(s) of the device or system under test to the inputs of the Model 1200.



- Set the FUNCTION Control to STEREO, the HIGH/LOW Range Selector to HIGH, and adjust the RANGE Attenuator until you get a reading closest to 0 dB on the meter(s), as shown in Fig. 17. Make a note of the value on the appropriate scale next to the RANGE knob pointer.

Fig. 17. To read the meter in this example, follow this procedure:

- Meter peak LED at 0 dB
- Note RANGE is HIGH
- Read HIGH scale for a 0 dB reading

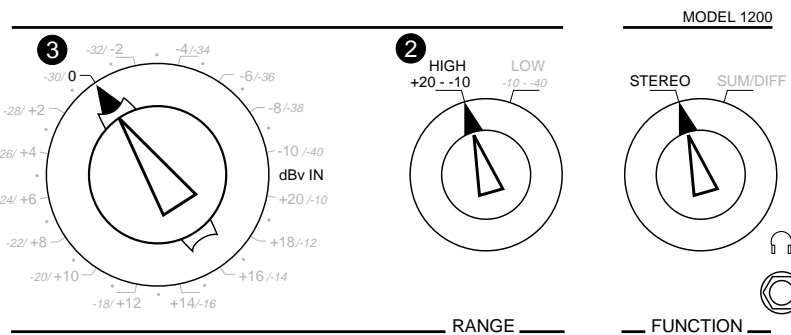
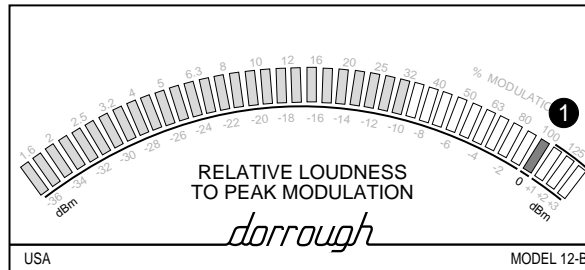

NOTE: Depending on the gain structure of the device or system under test, you may have to set the HIGH/LOW Range Selector to LOW to achieve a proper reading. For more information, refer to the Operation section.

- Turn off the test signal, set the HIGH/LOW Range Selector to LOW and adjust the RANGE Attenuator until you get a reading closest to 0 dB on the meter(s), as shown in Fig. 18 (page 17). Make a note of the value on the appropriate scale next to the RANGE knob pointer.
- The system noise floor is the difference between the two values noted in steps 5 and 4. Generally, this value is specified at a dB value below operating level (i.e., -36 dB below operating level).



NOTE: If a 0 dB reading cannot be obtained with the HIGH/LOW Range Selector set at LOW and the RANGE Attenuator set at -40 dB, note the reading on the meter and add the value to -40 db, as shown in Fig. 18. The system noise floor is the difference between this value and the one obtained in step 4.

Fig. 18. To read the meter in this example, follow this procedure:

- 1 - Meter peak LED at -30 dB
- 2 - Note RANGE is LOW
- 3 - Read LOW scale at -40 dB and add value from (1) for a total reading of -70 dB.

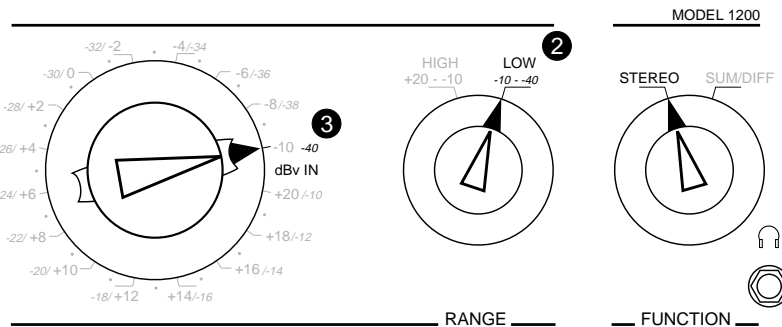
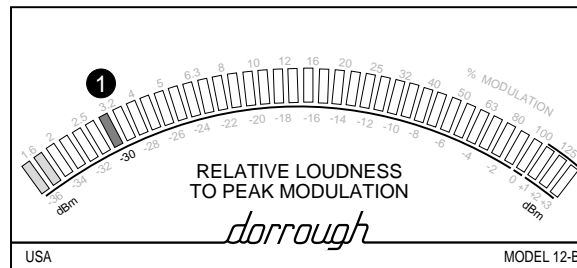

## Testing For Crosstalk

1. Feed a test signal (i.e., pink noise) at a standard line level to both channels of the device or system you wish to test.
- 2.. Adjust the gain of the device or system under test to its normal operation setting.
3. Connect or patch the channel output of the device or system under test to the inputs of the Model 1200.
4. Set the FUNCTION Control to STEREO, the HIGH/LOW Range Selector to HIGH, and adjust the RANGE Attenuator until you get a reading closest to 0 dB on the meter(s), as shown in Fig. 19 (page 18). Make a note of the value on the appropriate scale next to the RANGE knob pointer.



*NOTE: Depending on the gain structure of the device or system under test, you may have to set the HIGH/LOW Range Selector to LOW to achieve a proper reading. For more information, refer to the Operation section.*

5. Disconnect the RIGHT channel signal feed to the device or system being tested. Disconnect the LEFT output of the device or system being tested from the LEFT input of Model 1200.

Fig. 19. To read the meter in this example, follow this procedure:

- 1 - Meter peak LED at 0 dB
- 2 - Note RANGE is HIGH
- 3 - Read HIGH scale for a 0 dB reading

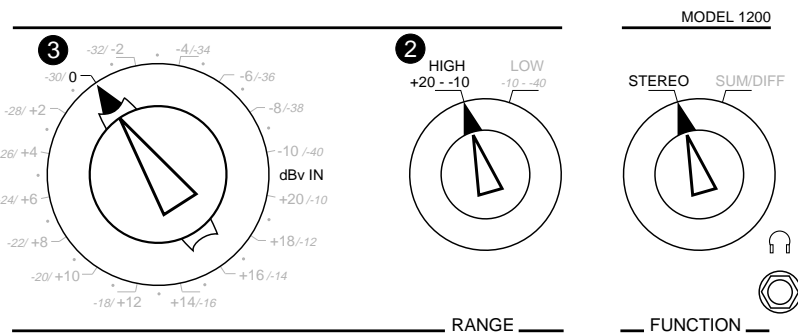
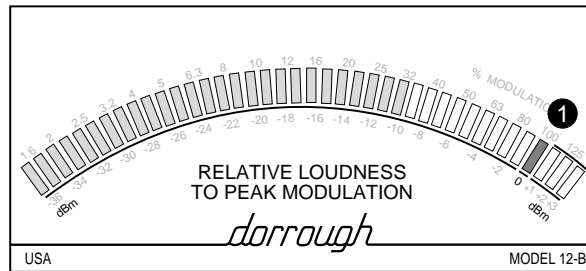

*NOTE: This action is necessary to avoid overloading the input circuits of the Model 1200 LEFT input channel as you perform the following steps.*

6. Set the HIGH/LOW Range Selector to LOW and adjust the RANGE Attenuator until you get a reading closest to 0 dB on the RIGHT meter, as shown in Fig. 20 (page 19). Make a note of the value on the appropriate scale next to the RANGE knob pointer.
7. LEFT Channel Crosstalk is the amount of signal crossing from the active LEFT channel circuitry into the inactive RIGHT channel, and is measured as the difference in values noted in steps 6 and 4. This value is specified at a dB value (i.e. -30 dB) below operating level.



*NOTE: If a 0 dB reading cannot be obtained with the HIGH/LOW Range Selector set at LOW and the RANGE Attenuator set at -40 dB, note the reading on the meter and add the value to -40 db, as shown earlier in Fig. 18. Crosstalk is then the difference between this value and the one obtained in step 4.*

8. To measure crosstalk in the RIGHT channel, repeat steps 1 through 6, except for a connection reversal in step 5.



*NOTE: In step 5, disconnect the LEFT channel signal feed to the device or system under test. Then disconnect the RIGHT output of the device or system being tested from the RIGHT input of Model 1200.*

Fig. 20. To read the meter in this example, follow this procedure:

- 1 - Meter peak LED at 0 dB
- 2 - Note RANGE is LOW
- 3 - Read LOW scale for a -30 dB reading

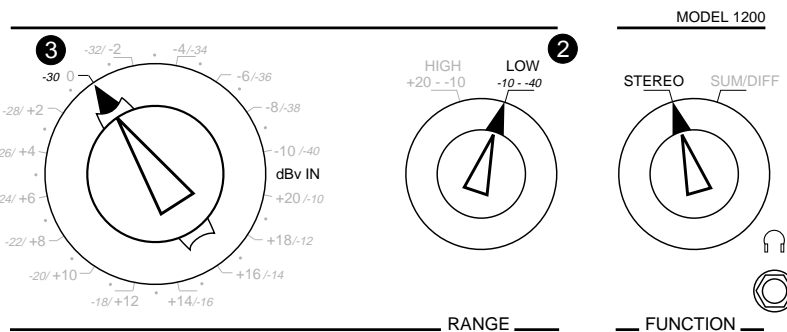
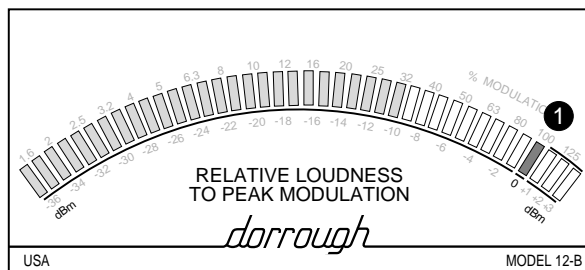

## Azimuth Adjustment

### Playback Azimuth

1. After performing a playback alignment of the analog tape recorder under test, locate a mid frequency tone (i.e. 1 kHz) on a playback alignment tape. Make sure the analog tape recorder is in the reproduce (tape) mode.
2. Connect or patch two channel outputs of the analog tape recorder under test to the inputs of the Model 1200.
3. Set the FUNCTION Control to SUM/DIFF, the HIGH/LOW Range Selector to HIGH, and adjust the RANGE Attenuator to -14 dB, as shown in Fig. 21 (page 20).
4. Place the analog tape recorder into the PLAY mode, and observe the LEFT/SUM meter as you adjust the reproduce head azimuth.

Fig. 21. To read the SUM meter in this example, follow this procedure:

- 1 - Meter peakLED at -14 dB
- 2 - Note RANGE is HIGH
- 3 - Read HIGH scale at +18 dB and add value from (1) for a total reading of +4 dB.

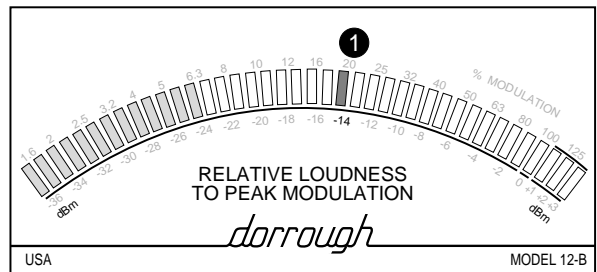

SUM

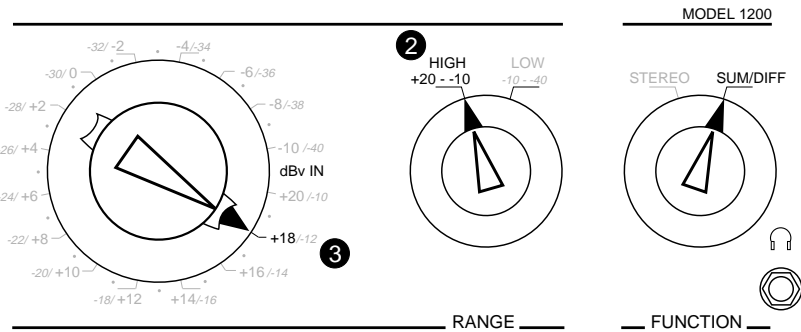

5. Continue the adjustment until you see a peak indication on the LEFT/SUM meter. At this point, observe the SUM/DIFF meter and adjust the reproduce azimuth until you see a minimum meter indication. For precise alignment, rotate the RANGE Attenuator clockwise, to read lower DIFF signals, and move the HIGH/LOW Range Selector to the LOW position, as shown in Fig. 22 (page 21).
6. Repeat steps 4 and 5 using a 8 kHz tone and then a 16 kHz tone located on the playback alignment tape.



*NOTE: This measurement will provide a minimal phase error reading for any two selected channels. For multi-track recorders (i.e., 8, 16, 24), look at the phase error response for several different channel pairs (i.e., 1 and 8, or 12 and 24) to achieve the best compromise in azimuth adjustment.*

## Record Azimuth

1. Feed a known mono test signal at a standard line level to two paralleled channel inputs of the analog tape recorder you wish to test. Make sure the analog tape recorder is in the reproduce (tape) mode.



*NOTE: Playback azimuth must be correctly set, since the following procedure relies on an accurate playback reference. If you are unsure of the playback azimuth setting, perform the Playback Azimuth procedure first.*

Fig. 22. To read the DIFF meter in this example, follow this procedure:

- 1 - Meter peak LED at -14 dB
- 2 - Note RANGE is LOW
- 3 - Read LOW scale at -40 dB and add value from (1) for a total reading of -54 dB

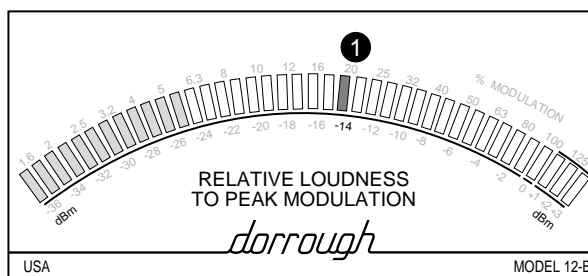

DIFF

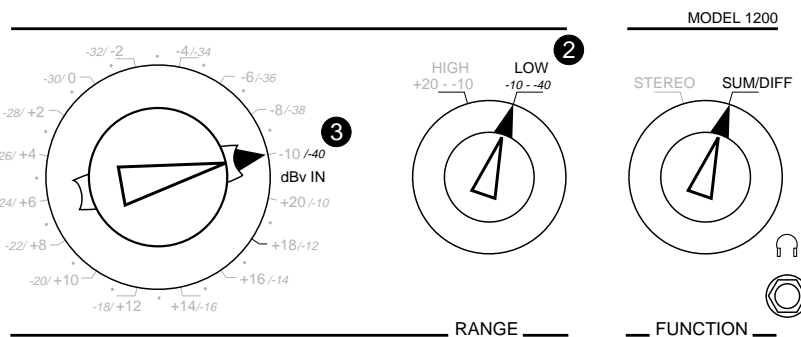

2. Use a blank, degaussed tape to record the test signal and adjust the record gain of the analog tape recorder for a normal operation setting. Adjust the individual channel record equalizers to achieve equal gain settings.
- ☞ *NOTE: Refer to your tape recorder owner's manual for specific information on test tone levels and frequencies used during a record alignment.*
3. Connect or patch the corresponding outputs of the analog tape recorder under test to the inputs of the Model 1200. Set Model 1200 Controls to those listed in step 3 of Playback Azimuth adjustment.
  4. Start and place the analog tape recorder into RECORD, and observe the LEFT/SUM meter as you adjust record head azimuth.
  5. Continue the adjustment until you see a peak indication on the LEFT/SUM meter. At this point, observe the SUM/DIFF meter and adjust the record azimuth until you see a minimum meter indication. For precise alignment, rotate the RANGE Attenuator clockwise to read lower DIFF signals and move the HIGH/LOW Range Selector to the LOW position, as shown in Fig. 22.

☞ *NOTE: This measurement will provide a minimal phase error reading for the two selected channels. For multi-track recorders (i.e., 8, 16, 24), look at the phase error response for several different channel pairs (i.e., 1 and 8, or 12 and 24) to achieve the best compromise in azimuth adjustment.*

## **Phase Polarity Compatibility of Music/Dialog/Effects**

In general, most television broadcast networks require mono dialog that is center-panned in an overall mix (although left/right panning may be used for effect). Effects are either mono panned for left/right perspective, or are true stereo recordings done with a M-S microphone. Music is almost always stereo and is made of mono panned instruments, synthetic stereo processing (i.e. digital reverb), and true stereo pickups (i.e. M-S microphone on an acoustic piano or vocal chorus).

Mono compatibility problems can occur when these elements are combined into a stereo mix. With the DORROUGH Stereo Test Set, you can check the phase polarity compatibility prior to broadcast or duplication of the individual elements or combinations of dialog, effects, and music during the mixing process.

By using a combination of the techniques discussed earlier in Applications on Testing For L/R Polarity and Phase Compatibility and Testing Stereo Signals, you also can quickly verify whether the sound elements will sum correctly in mono during a stereo mix.

For example, use the Model 1200 to set levels of panned effects in a stereo mix. Leave the FUNCTION Control in the SUM/DIFF position and observe the mono sum as you build your mix. While adjusting the level of a center-panned effect, observe the SUM/DIFF reading to see the mono compatible result. Compare the SUM/DIFF reading of this effect against those panned to extreme right and left positions. A large discrepancy in meter readings means the center-panned effect will be louder than the others in mono.

## **Determining the Need for Dynamic Signal Processing**

Use the Model 1200 to measure peak signal excursions of audio material that is going to be broadcast or duplicated. If the meters indicate peak levels above your chosen reference (i.e. +4 dB = 100% modulation), you know that compression and/or limiting is required.

Once you have inserted a compressor/limiter in the audio chain, observe the Model 1200 meters as you adjust the compression threshold, ratio, attack/release, and gain controls.

With the DORROUGH Stereo Test Set, you can satisfy the broadcast or duplication technical requirements, yet achieve better-sounding audio with minimal use of the right combination of compressor/limiter controls.

For example, use the Model 1200 to observe the signal action of your station's STL compressor. Under ideal conditions, you should see a decrease in the range between the peak and average readings when the compressor is on-line. If you observe an increase in this range, then the compressor attack/release controls need to be adjusted for a faster response time. If an adjustment does not improve this condition, suspect an equipment malfunction or poor design.

# CIRCUIT THEORY

The circuits that make up the DORROUGH Stereo Signal Test Set, Model 1200, are grouped onto two circuit boards and one sub-assembly: an Input Matrix Board, a Power Supply Board, and a dual Model 12-B Panel Meter Sub-Assembly, as shown in Fig. 23.

The first part of this section is devoted to a description of the Model 1200 circuits, while the second half details the theory behind the DORROUGH Model 12-B panel meter circuits.

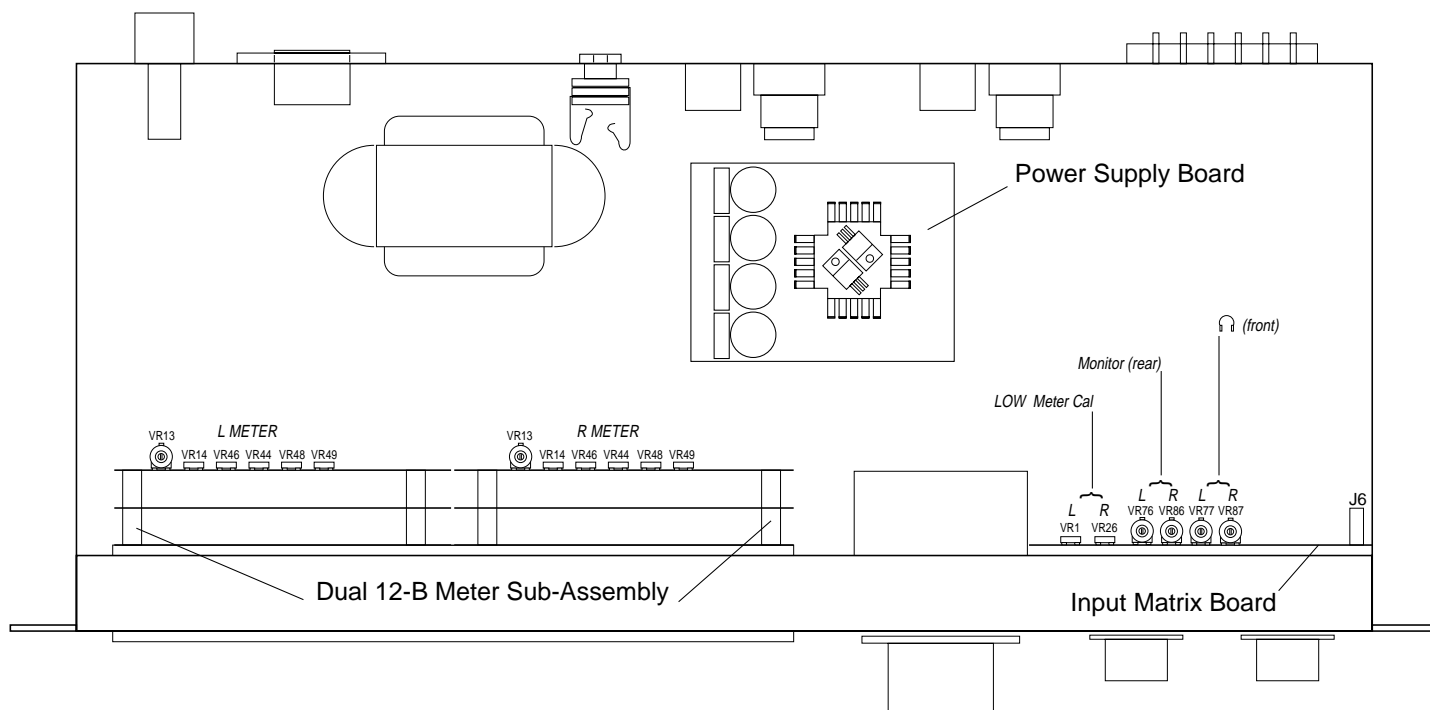

Fig. 23. Simplified top view of Model 1200 internal chassis layout.

## Model 1200 Circuits

A block diagram, shown in Fig. 24 (page 24), shows the overall signal flow for the Model 1200. Refer to this diagram, as well as the circuit schematic (back of the manual), throughout the following discussion.

The inputs feed left and right servo-balanced differential amplifiers (U1 and U26) that each have a preset gain of +30 dB and an input impedance of 40 kOhms. The HIGH/LOW Range Selector (front panel) reduces the gain to unity whenever LOW is selected.

The outputs of the differential amplifiers are routed to the FUNCTION Control (front control), as well as a pair of summing amplifiers (U51). These amplifiers provide sum and difference results that also feed the FUNCTION Control.



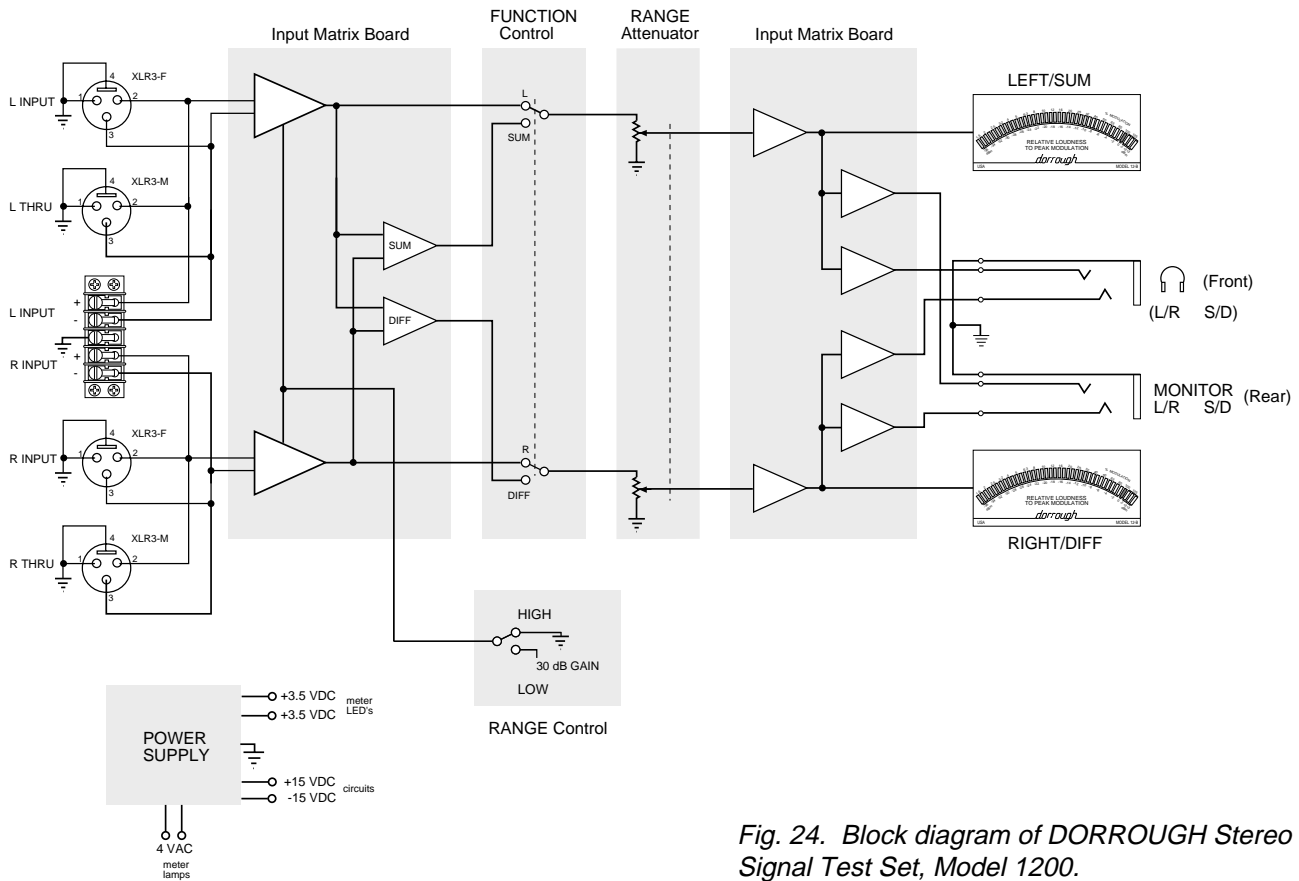

Fig. 24. Block diagram of DORROUGH Stereo Signal Test Set, Model 1200.

The output of the FUNCTION Control feeds the selected signals (L/R or SUM/DIFF) to the RANGE Attenuator (front panel). This control is a precision 30 dB attenuator, having a -1 dB step for each clockwise indent.

The output of the RANGE Attenuator is routed to the Model 12-B Panel Meter Sub-Assembly and two pairs of Monitor amplifiers U76 and U77) whose outputs appear on the front and rear panels. The front panel Monitor output is fed by a 1 W amplifier (U77) and is sufficient for driving headphones or a set of small speakers. The rear panel Monitor output should only be used for test equipment monitoring.

VR76 (L or SUM) and VR86 (R or DIFF) provide level adjustment of amplifiers outputs at the rear panel jack. VR77 (L or SUM) and VR87 (R or DIFF) provide level adjustment of the amplifier outputs at the front panel jack.

The Power Supply Board provides the following voltages: regulated bipolar 15 VDC, unregulated 3.5 VDC, and 4 VAC. The regulated bipolar 15 VDC is used to power the processing circuits on the Input Matrix Board and the dual Model 12-B Meter Sub assembly.

The unregulated 3.5 VDC is used to power the bargraph LED's on the Model 12-B meters. The 4 VAC powers the front panel meter illumination lamps.

## Model 12-B Meter Circuits

The circuits that make up the DORROUGH Relative Loudness to Peak Modulation meter) are grouped onto two circuit boards: an Input Signal Processing Board, and a Bar and Peak Driver Circuit Board. Power is supplied by the Power Supply Board. A block diagram, shown in Fig. 25, discloses the circuit elements and connections in a simplified form. Refer to this diagram, as well as the circuit schematics (located at the end of this manual), throughout the following discussion.

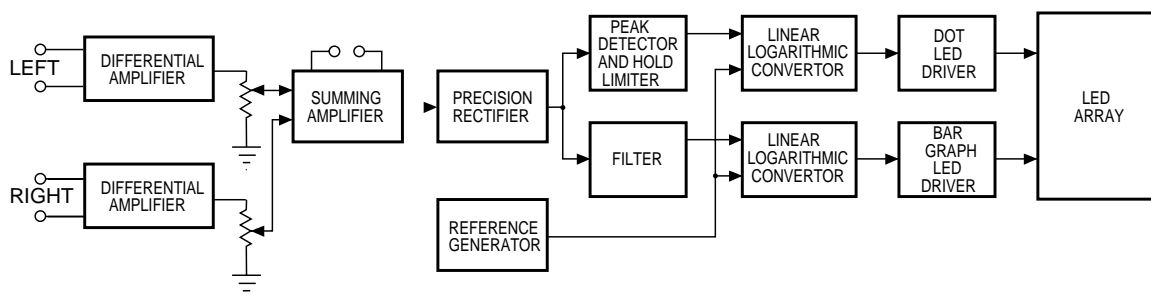

Fig. 25. Block diagram of Model 12-B meter.

The input is fed into the left and right differential amplifiers. The differential inputs are configured so that the input impedance is 20K, for balanced inputs and 10K for unbalanced inputs (negative terminal is grounded for unbalanced operation).

The left input level is controlled by R-13 and the right input by R-14. The output of these two controls are fed to a summing amplifier. The feedback resistor R-18 controls the input sensitivity of the instrument. As shipped, the value of R-18 is 20K which provides an input sensitivity of -18 dBm. Changing the value of R-18 to 100K increases the sensitivity to -30 dBm.

The output of the summing amplifier feeds a precision rectifier. The output of the precision rectifier feeds a split to PEAK and PERSISTENCE circuits.

Since the desired display is to be logarithmic, the signals are fed to corresponding "linear/logarithmic" converters. The outputs of these converters feed the display drivers. The driver for the PEAK display is configured as a dot, while the driver for the PERSISTENCE display is configured as a bargraph.

Each of the 40 LEDs derives an input from both of the drivers. A steady state sine-wave will illuminate a bargraph at a given amplitude, with the last-displayed LED brighter than the remainder. This gives an indication that the amplitude of the PERSISTENCE and the amplitude of the PEAK are equal, showing proper alignment of the instrument.

# FIELD ALIGNMENT

To occasionally check the accuracy of your DORROUGH Stereo Signal Test Set, perform the Field Alignment listed in this section.

- \* \* \* **IMPORTANT:** *The following alignment assumes the Model 12-B meters are reading accurately. Although the meters are designed for exceptionally stable performance, you may want to satisfy your curiosity or verify performance after a repair has been made. In that case, perform the Model 12-B Alignment Procedure first. Once you are satisfied that the meters are reading correctly, then proceed to the Model 1200 Alignment Procedure.*

## Model 1200 Alignment Procedure



**NOTE:** *The designators listed in the following procedure refer to parts contained on a single meter p.c. board, and therefore apply to the alignment of either the Left or Right channel.*

Refer to the schematic, Fig. 23, and Fig. 24 for circuit board part locations as you perform the following instructions.

1. Connect a 1 kHz sinusoidal source at 0 dB to the Left terminal or XLR on the rear panel.
2. Set the FUNCTION Control to STEREO, the HIGH/LOW RANGE Selector to HIGH, and the RANGE Attenuator to 0 dB.
3. Observe the left meter and verify a 0 dB indication. If the meter is not reading 0 dB, adjust VR-13 on the Left meter signal board until 0 dB is achieved.
4. Move the test signal to the Right terminal or XLR and repeat step 3 for the Right meter.
5. Lower the test signal to -30 dB, set the HIGH/LOW RANGE Selector to LOW and position the RANGE Attenuator to -30 dB.
6. Observe the Right meter and verify a 0 dB indication. If the meter is not reading 0 dB, adjust VR-26 on the Input Matrix Board until 0 dB is achieved.
7. Move the test signal back to the Left terminal or XLR. Observe the Left meter and verify a 0 dB indication. If the meter is not reading 0 dB, adjust VR 1 on the Input Matrix Board until 0 dB is achieved.

## Model 12-B Alignment Procedure

All adjustments for the alignment of the LED display are located on the dual Model 12-B Panel Meter Sub-Assembly.



*NOTE: The designators listed in the following procedure refer to parts contained on a single meter p.c. board, and therefore apply to the alignment of either the Left or Right meter.*

Refer to the schematic, Fig. 23, and Fig. 24 for circuit board part locations as you perform the following instructions.

### Left Meter Alignment

1. With the power off, disconnect the ribbon cable from J6 (top of board next to trim pots) on the Input Matrix Board.
2. Connect a 1 kHz sinusoidal signal source at -10 dB to pin 4 on J6 to feed the Left meter. Use the sleeve connection on the rear panel Monitor jack to attach the ground test lead. Apply power and turn the Right meter input level control (VR14) fully counterclockwise.
3. Adjust the Left input gain control VR-13 so that DS-1 is off and DS-2, -3, -4 are on. Refer to Fig. 26 for DS1-4 locations on meter signal board.

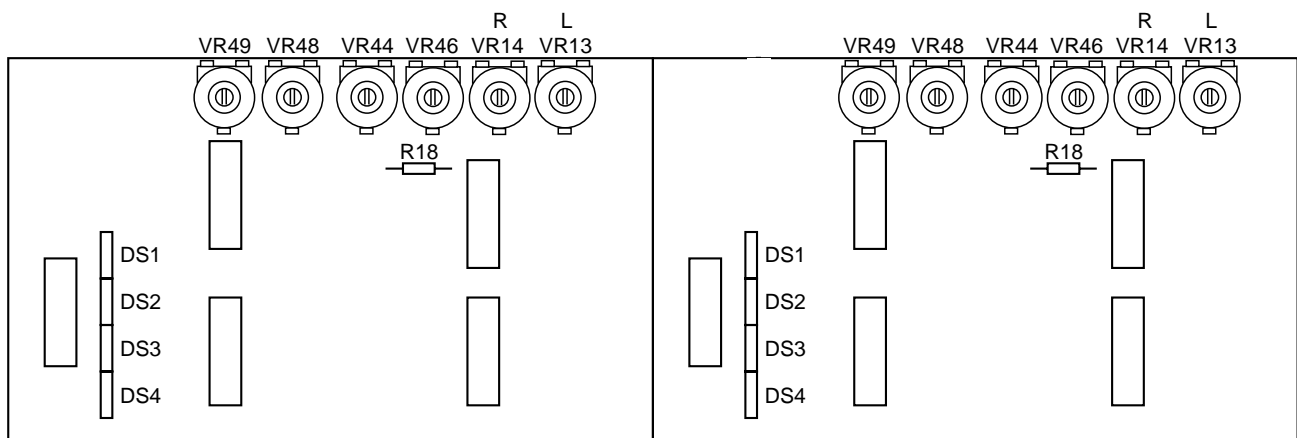

Fig. 26. Simplified component view of Model 12-B signal boards.

4. Adjust the input signal to -25 dB.
5. Adjust the low PERSISTENCE level control VR-44 so that only the first LED (-36 dB on meter scale) at the bottom of the PERSISTENCE scale is illuminated.

6. Adjust the low PEAK level control VR-46 so only the first LED (-36 dB on meter scale) at the bottom of the PERSISTENCE scale brightens.



*NOTE: This indicates that both the PEAK and the PERSISTENCE drivers are providing current to this LED.*

7. Change the input signal to +5 dB (a 30 dB increase).
8. Adjust the high PERSISTENCE level control VR-48 so that the bargraph illuminates LEDs up to and including the -6 dB LED.
9. Adjust the high PEAK level control VR-49 until the -6 dB LED brightens.



*NOTE: This indicates that both the PEAK and the PERSISTENCE drivers are both providing current to this LED.*

10. Increase input signal to +14 dB and observe that the +3 dB LED illuminates.



*NOTE: The +3 dB LED should indicate drive from both PEAK and PERSISTENCE drivers.*

11. Decrease input signal to +13 dB; observe that the +3 dB LED turns off.
12. Decrease input signal to +4 dB and adjust VR-13 for -11 dB on the scale.
13. Then, feed input signal of +4 dB to Right input terminals, and adjust VR-14 for -11 dB on the scale. This duplicates the factory settings.

### **Right Meter Alignment**

14. Move the 1 kHz sinusoidal signal source at -10 dB to pin 6 on J6 to feed the Right meter. Turn the Left meter input level control (VR14) fully counterclockwise.
15. Repeat steps 3 through 13 for the Right meter.